

ChamPro®



WALL MOUNTED WOOD RACK
MODEL NO: CWMWR1
PART NO: 7640030

USER INSTRUCTIONS

INTRODUCTION

Thank you for purchasing this CLARKE Wood Rack.

Please read this manual thoroughly and follow the instructions carefully. In doing so you will ensure the safety of yourself and others around you, and you can look forward to the product giving you long & satisfactory service.

TECHNICAL DATA

Vertical height 99.5 cm

Shelf Depth 29.5 cm

Max load capacity 50 kg per level (total 300 kg)

CONTENTS

2 x Vertical Bars 6 x Spacers 12 x Horizontal Bars 12 x Screws

GENERAL SAFETY PRECAUTIONS

- NEVER load the rack with more than the maximum safe working load.
- ENSURE that the rack is installed in a location strong enough to take the
- combined weight of the rack and whatever is being stored on it.
- ALWAYS check for damage before use. Any damage should be properly repaired or the part replaced. If in doubt, do not use. Consult your dealer.
- ENSURE that the weight is evenly distributed across the full width
- ALWAYS keep the storage area tidy. Cluttered areas invite accidents.
- ALWAYS ensure that adequate lighting is available and well positioned.
- NEVER swing or climb on the wood rack.
- ALWAYS fix the rack to a solid wall able to take load of 6 x 50 kg = 300 kg.
- ALWAYS distribute any heavy loads evenly across the rack.
- **Please keep these instructions in a safe place for future reference.**

ENVIRONMENTAL PROTECTION

If broken, do not dispose of this product with general household waste. This product contains valuable raw materials and should be disposed of appropriately at a recognised disposal facility.

ASSEMBLY & FIXING INSTRUCTIONS

1. Insert a screw into the lowest screw-hole in the vertical bar. Take one of the horizontal bars and slide it down the vertical bar with the notch on the lower side until it rests in position against the screw.
2. Insert a screw into the next hole up and install the next horizontal bar. Repeat until all the bars are installed.
3. Mark the positions of the fixing holes accurately on the wall using the vertical bars as templates to mark the drilling locations.

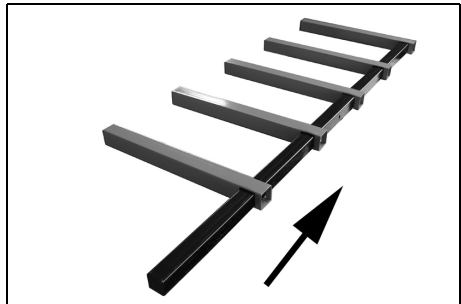
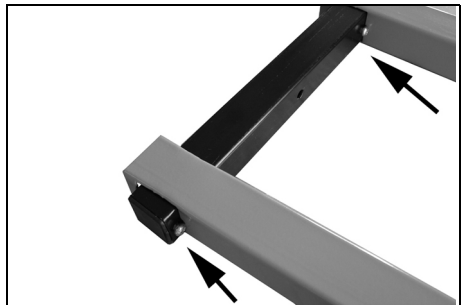

NOTE: The optimum distance apart between the two vertical bars is dependant upon the size and weight of the objects/ materials being stored. For longer materials or greater weight, multiple wood racks can be used.

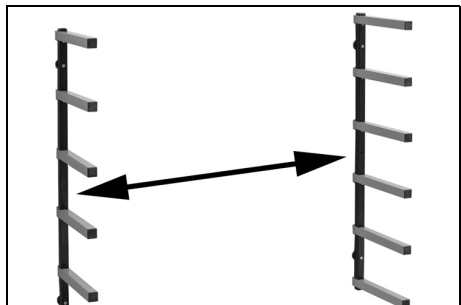

4. Position the spacers between the mounting holes and the wall, and fasten to the wall using suitable fixings.

NOTE: You will need to provide screws and wall plugs of the correct type, able to adequately support the weight you intend to place on the rack.

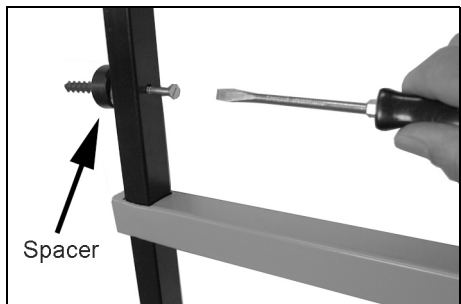

5. When installing on **dry-lining (stud) walls**, take care to ensure fixing into a solid structural member. Fixings should always be located in the centre of the wall studs.
6. When installing on **masonry walls**, use (6mm) wall plugs. The vertical bars of the wall rack are 41 mm thick. Therefore fixings of at least 70 mm length are suitable. Always use suitable masonry bits and a hammer drill for drilling into solid walls.
7. When installing on **steel walled sheds**, mount the wall rack in such a way that the weight is correctly transferred to the wall structure, such as by fixing to the vertical framework.
8. When installing on **timber fencing**, structural reinforcement will be required if the fence was not designed to carry load. A combination of horizontal and vertical supports may easily be added and the wall rack fixed using 70mm woodscrews.

GUARANTEE

This product is guaranteed against faulty manufacture for a period of 12 months from the date of purchase. Please keep your receipt which will be required as proof of purchase.

This guarantee is invalid if the product is found to have been abused or tampered with in any way, or not used for its intended purpose. Faulty goods should be returned to their place of purchase. No product can be returned to us without prior permission.

This guarantee does not effect your statutory rights.

A SELECTION FROM THE VAST RANGE OF



QUALITY PRODUCTS

AIR COMPRESSORS

From DIY to industrial, Plus air tools, spray guns and accessories.

GENERATORS

Prime duty or emergency standby for business, home and leisure.

POWER WASHERS

Hot and cold, electric and engine driven - we have what you need

WELDERS

Mig, Arc, Tig and Spot. From DIY to auto/industrial.

METALWORKING

Drills, grinders and saws for DIY and professional use.

WOODWORKING

Saws, sanders, lathes, mortisers and dust extraction.

HYDRAULICS

Cranes, body repair kits, transmission jacks for all types of workshop use.

WATER PUMPS

Submersible, electric and engine driven for DIY, agriculture and industry.

POWER TOOLS

Angle grinders, cordless drill sets, saws and sanders.

STARTERS/CHARGERS

All sizes for car and commercial use.